

# Specifications

Hydraulic Rough Terrain Crane

## RTC-8035

**35-ton (31.5 metric ton)**

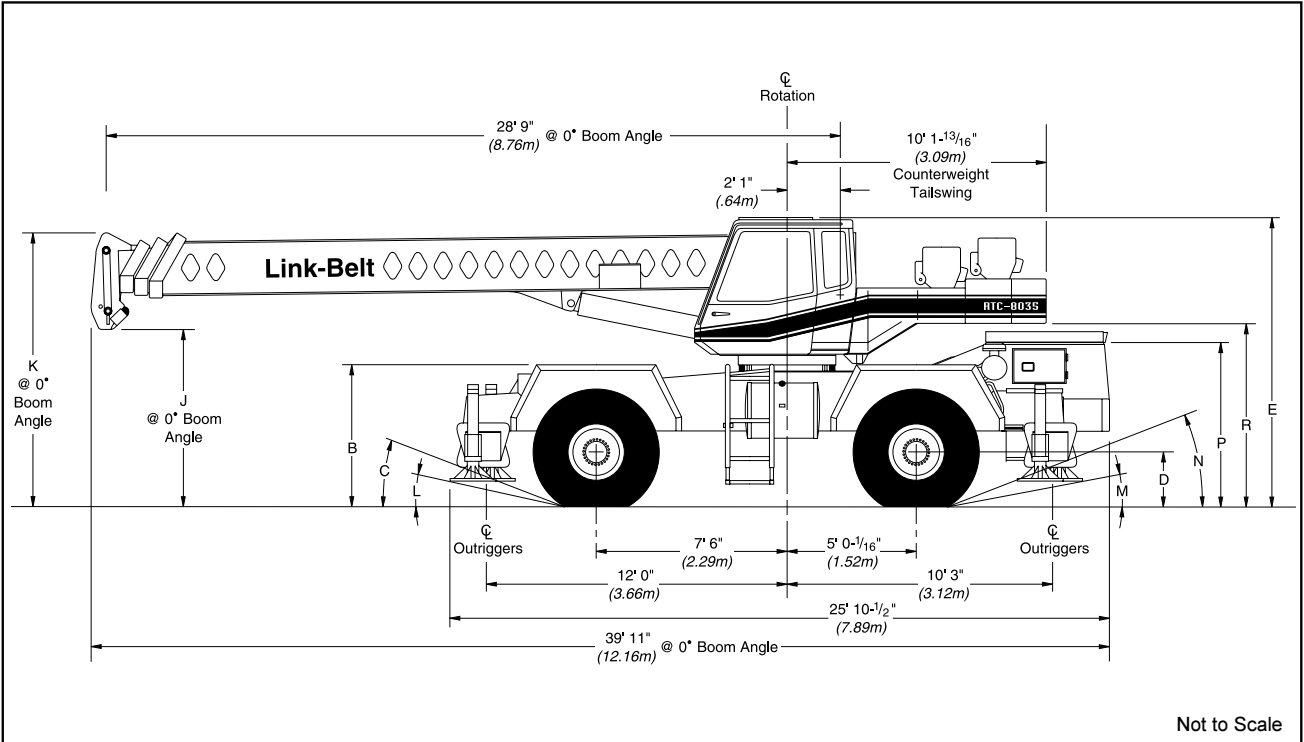

Not to Scale

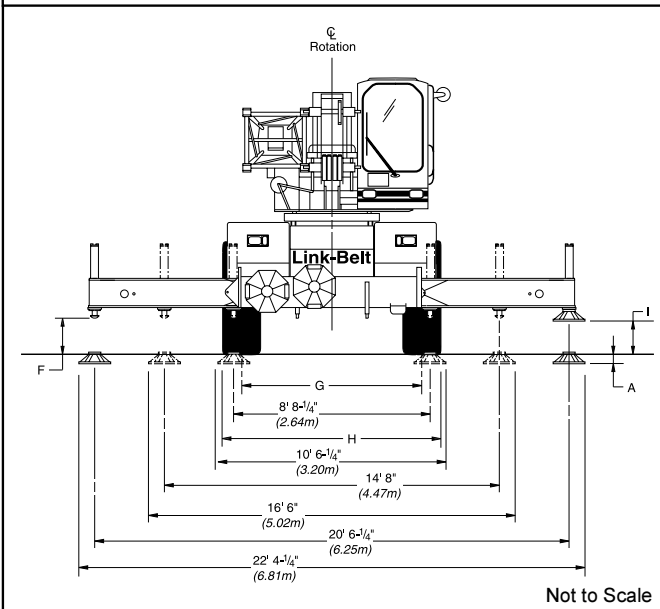

Not to Scale

General dimensions	feet	meters
Turning radius (4-wheel steer - centerline of tires)	18' 8"	5.70
Turning radius (2-wheel steer - centerline of tires)	33' 11"	10.33
Turning radius (4-wheel steer - wall to wall)	29' 10"	9.08
Turning radius (2-wheel steer - wall to wall)	43' 1"	13.14
Turning radius (4-wheel steer - carrier clearance)	22' 1"	6.74

Tires	23.5 X 25 (20-PR)	
	inches	meters
A	11.10"	.28
B	69.78"	1.77
C	22.6°	-
D	27.73"	.70
E	138.67"	3.52
F	18.40"	.47
G	88.50"	2.25
H	114.00"	2.90
I	11.84"	.30
J	89.98"	2.29
K	134.98"	3.43
L	12.2°	-
M	10.6°	-
N	19.2°	-
P	79.94"	2.03
R	87.86"	2.23

# Upperstructure

## ■ Boom

**Patented Design.** All boom section side plates have diamond shaped impressions for superior strength to weight ratio and 100,000 p.s.i. (689.5 MPa) steel angle chords for lateral stiffness. Boom telescope sections are supported by wear shoes both vertically and horizontally to prevent metal to metal contact.

### Microguard 434, Rated Capacity Limiter - Standard;

Graphic, audio-visual warning system built into corner post with anti-two block and function limiters. Operating data available includes boom length, boom angle, head height, radius of load, machine configuration, allowed load, actual load and percent of allowed load. Presettable alarms for maximum and minimum boom angles, max. tip height, max. boom length, swing left/right positions. Operator defined area alarm is also provided. Anti-two block weight designed for quick reeve of hookblock.

*Optional;* Load rating bar graph for quick operator reference.

**Standard Boom** - 28' 9" - 91' 0" (8.76 - 27.74 m) four-section full power boom. Two mode boom extension - Basic mode (or mode 'B') is the full power, synchronized mode of telescoping all sections proportionally. The exclusive *A*-max mode (or mode 'A') extends only the inner mid-section to 49' 6" (15.09 m) offering increased capacities for in-close, maximum capacity picks.

**Boom head** - Four 10-5/8" (0.27 m) root diameter nylon sheaves handle up to 8 parts of wire rope. Rope dead end lugs provided on each side of boom head. Easily removable wire rope guards are standard. Boom head designed for quick reeve of hookblock.

**Auxiliary lifting sheave** - *Optional;* Single 10-5/8" (0.27 m) root diameter nylon sheave with removable wire rope guard. For use with one or two parts of line off the optional auxiliary winch. Does not affect erection of fly or use of main head sheaves for multiple reeving.

**Boom elevation** - One Link-Belt designed hydraulic cylinder with holding valve and bushings in each end. Hand control for controlling boom elevation from -3° to +79.9°.

## ■ Fly

*Optional* - 25' (7.62 m) fixed stowable one piece lattice type.

*Optional* - 25' (7.62 m) offsettable (2°, 15°, or 30°) stowable one-piece lattice type.

*Optional* - 25' - 43' (7.62 m - 13.10 m) offsettable (2°, 15°, or 30°) stowable lattice type with telescoping box section.

## ■ Cab and Controls

Environmental ULTRA-CAB™ of LFC•2000 construction process featuring laminated fibrous composite material; isolated from sound with acoustical fabric insulation providing 82 dBA sound level, all tinted and tempered safety glass windows. Sliding rear and right side windows and swing up roof window for maximum visibility and ventilation. Slide-by-door opens to 36" (0.91 m) width. 6-way adjustable operator's seat for maximum operator comfort. Hydraulic control levers (joystick type) for swing, winches and boomhoist. Outtrigger controls conveniently located in overhead control console; sight level bubble also provided in upper cab. Foot controls for boom telescope, swing brake, travel brake and engine throttle.

**Cab instrumentation** - Corner post mounted gauges for hydraulic oil temperature, air pressure, fuel, tachometer, water temperature, voltmeter and oil pressure. Converter oil temperature gauge mounted in side console.

## ■ Swing

Bi-directional hydraulic swing motor mounted to a planetary reducer for 360° continuous smooth swing at 3.6 r.p.m.

**Swing parking brake** - 360°, electric over hydraulic (spring applied, hydraulic released) multi-disc brake mounted on the speed reducer. Operated by toggle switch in overhead control console.

**Swing brake** - 360°, foot operated, hydraulic applied disc brake mounted on the speed reducer.

**Travel swing lock** - Standard; two position travel swing lock (pin device) operated from the operator's cab.

**Counterweight** - Bolted to upperstructure frame. 9,750 lb. (4 422 kg) cwt. on machines with two hoist drums; 10,615 lb. (4 814 kg) cwt. on one drum machines.

## ■ Hydraulic System

**Main pump** - 2-section gear type pump. Combined pump capacity 75 gpm (283.8 lpm). Torque converter mounted pump powered by engine through a pump disconnect. Pump disconnect is engaged/disengaged from carrier. Section one operates winch circuit @ max. pressure of 3,500 p.s.i. (246 kg/cm<sup>2</sup>). Section two operates boom hoist and telescope circuits @ max. pressure of 3,100 p.s.i. (218 kg/cm<sup>2</sup>).

**Swing / outrigger / steering pump** - Single gear-type pump, 18 gpm (68.13 lpm) maximum. Torque converter mounted

pump powered by engine. Pump operates at 2,500 p.s.i. (175 kg/cm<sup>2</sup>).

The three pump hydraulic circuit allows simultaneous operation of the three main crane functions (winch, boom hoist, swing) without any function interference.

**Reservoir** - 110 gallon (416.39 L) capacity. One diffuser for deaeration.

**Filtration** - One 10-micron filter located inside hydraulic reservoir. Accessible for easy replacement.

**Control valves** - Five separate pilot operated control valves allow simultaneous operation of all crane functions.

## ■ Load Hoist System

**Standard** - 2M main winch with two-speed motor, automatic brake and electronic drum rotation indicator; power up/down mode of operation. Bi-directional piston-type hydraulic motor, driven through a planetary reduction unit for positive control under all load conditions.

*Optional* - Model 1M main winch with one-speed motor and automatic brake, power up/down mode of operation.

*Optional* - Model 1M auxiliary winch with one-speed motor and automatic brake, power up/down mode of operation.

*Optional* - Model 2M auxiliary winch with two-speed motor and automatic brake, power up/down mode of operation.

**Line pulls and speeds** - Maximum line pull 10,360 lbs. (4 699 kg) and maximum line speed of 473 f.p.m. (144 m/min) on standard 10-5/8" (0.27 m) root diameter grooved drum.

## ■ Additional Equipment - Standard

Fire extinguisher, seat belt, horn, dome light, mirrors, tilt/telescoping steering wheel, electric windshield wiper/washer, rooftop window electric wiper, defroster fan, backup alarm, audible swing alarm, cab-mounted work lights, and rotation resistant wire rope.

## ■ Additional Upperstructure Equipment - Optional

360° swing lock (meets New York City requirements), single axis controls, diesel or hydraulic heater, air conditioning, 35-ton (31.77 metric ton), 15-ton (13.6 metric ton), or 25-ton (22.7 metric ton) quick reeve hook blocks, 8-1/2-ton (7.71 metric ton) hook ball, engine monitoring system, amber rotating beacon, boom floodlight, drum cable follower, and 3rd wrap drum indicator.

# Carrier

## ■ Type

9' 6" (2.89 m) wide, 150" (3.81 m) wheelbase.

4 x 4 x 4 - (4-wheel steer, 4-wheel drive)  
**Standard** - For rough terrain with limited turning area.

**Frame** - 100,000 p.s.i. (689.5 MPa) steel, double walled construction with integral 100,000 p.s.i. (689.5 MPa) steel outrigger boxes.

## ■ Axles

**Front** - Standard; heavy duty planetary drive/steer type.

**Rear** - Standard; heavy duty planetary drive/steer type.

**Front/Rear** - *Optional*; driver controlled differential lock for high traction.

## ■ Suspension

**Front axle** - Rigid mounted to frame.

**Rear axle** - Pin-mounted on welded steel box cradle. Automatic hydraulic rear axle oscillation lock-out engages when upperstructure rotates past 2-1/2° of centerline.

## ■ Tires

**Front and Rear**  
Standard - 23.5 x 25 (20-PR) Earthmover type.

## ■ Brakes

**Service** - Air over hydraulic, disc type brakes at each wheel end.

**Parking/emergency** - Disc caliper type spring applied, air released, fade resistant; cab controlled, mounted on front axle.

## ■ Steering

Hydraulic two wheel, four wheel and "crab" steering: controlled from steering wheel.

## ■ Transmission

Clark three-speed two range power shift transmission. Six speeds available forward and reverse. Front axle disconnect for two or four-wheel drive.

## ■ Outriggers

Three position (fully extended, intermediate and fully retracted) operation capability. Four hydraulic, telescoping beam and jack outriggers. Vertical jack cylinders equipped with integral holding valve. Beams extend to 20' 6-1/4" (6.25 m) centerline-to-centerline and retract to within 9' 6" (2.90 m) overall width. Equipped with stowable, lightweight 22" (0.56 m) octagonal aluminum floats. Controls and sight level bubble located in upperstructure cab.

Confined Area Lift Capacities (CALC) System - Outrigger may be extended to an intermediate position for working in confined areas. Extend position levers located on outrigger boxes allow the outrigger beams to be fully extended or limits them to intermediate position based on the selected position.

## ■ Additional Equipment - Standard

Cab steps, front, side, and rear carrier steps, electronic controlled front axle disconnect, skid resistant finish on carrier deck, front storage, fenders, pontoon storage, full travel lighting package, throttle lock, hour meter, air chucks, and lifting/tie down lugs.

## ■ Additional Equipment - Optional

Differential lock on both axles, front and rear towing shackles, propane fired engine block heater, ether injection package, air dryer, spare tires and rims, front and rear mounted pintle hooks, outrigger cover package, emergency steering system, rear steer indicator, and carrier mounted winch, 24 volt start and tire inflation kit.

## Travel speeds and gradeability

Engine	Tires	Maximum Speed		Gradeability at stall	Maximum tractive effort at stall		Gradeability at 1.0 mph (1.61 km/h)	Maximum tractive effort at 1.0 mph (1.61 km/h)	
		mph	km/h		pounds	kg		pounds	kg
Cummins 6BT 5.9	23.5 X 25	21.1	34.0	72.3%	38,240	17 346	47.0%	28,069	12 732

Engine	Cummins 6BT 5.9
Cylinders - cycle	6 - 4
Bore	4.02" (102.1 mm)
Stroke	4.72" (119.9 mm)
Displacement	359 cu. in. (5 884 cm <sup>3</sup> )
Maximum brake hp	152 @ 2500 rpm
Peak torque	400 ft. lbs. (542 J)
Electric system	12 volt
Fuel capacity	75 gallons (284 L)
Alternator	130 amps
Crankcase capacity	17.3 qts. (16.4 L)

### Axle loads

Base machine with standard 28' 9" - 91' 0" (8.76 m - 27.74 m) four-section full power boom, 2M main winch with 2-speed hoisting and power up/down, 450' (137.16 m) 5/8" (16 mm) wire rope, 4x4x4 carrier with Cummins 6BT 5.9 engine, 23.5 X 25.0 tires, full fuel and counterweight.	G.V.W. <sup>①</sup>		Upper facing front				Upper facing rear			
			Front axle		Rear axle		Front axle		Rear axle	
	lbs.	kg	lbs.	kg	lbs.	kg	lbs.	kg	lbs.	kg
	57,785	26 210	25,323	11 486	32,462	14 724	20,321	9 217	37,464	16 993
Cold weather starting aids - propane heater and ether injector	48	22	6	3	42	19	6	3	42	19
Tow shackles	39	17	18	8	21	9	18	8	21	9
Pintle hook, front	20	9	28	13	-8	-4	28	13	-8	-4
Outrigger cover package	110	50	52	24	58	26	52	24	58	26
Carrier mounted winch	686	311	923	419	-237	-108	923	419	-237	-108
Winch roller - front	76	34	-14	-7	90	41	75	33.5	1	.5
Winch roller - rear	76	34	-1	-.5	77	34.5	62	28	14	6
1M main winch	-24	-11	6	3	-30	-14	-25	-11.5	1	.5
1M auxiliary winch	-232	-105	17	8	-249	-113	-202	-91	-30	-14
2M auxiliary winch	-210	-95	15	7	-225	-102	-183	-83	-27	-12
350' (106.7 m) wire rope on auxiliary winch	286	130	-24	-11	310	141	253	115	33	15
Hydraulic heater	110	50	22	10	88	40	66	30	44	20
Diesel heater	70	32	16	7	54	25	40	18	30	14
Fly brackets to boom base section for fly options	113	51	156	71	-43	-20	-66	-30	179	81
25' (11.34 m) fixed fly (stowed)	544	247	794	360	-250	-113	-359	-163	903	410
25' (11.34 m) offsettable fly (stowed)	1,002	455	1,492	677	-490	-222	-690	-313	1,692	768
25' - 43' (11.34 - 13.11 m) offsettable fly (stowed)	1,492	677	2,206	1 001	-714	-324	-1,013	-460	2,505	1 137
Floodlight on boom base section	4	2	7	3	-3	-1	-4	-2	7	3
35-ton hookblock to front bumper	780	354	1,108	503	-328	-149	-	-	-	-
Hookball to front bumper	360	163	511	232	-151	-69	-	-	-	-
Auxiliary arm	60	27	157	71	-97	-44	-109	-50	169	77

① Adjust gross vehicle weight & axle loading according to component weight.

Note: All weights are ± 3%

Tire	Max. Axle Load @ 20 mph (32.7 km/hr)
23.5 x 25 (20-PR)	33,000 lbs. (14 969 kg)

Link-Belt Construction Equipment Company Lexington, Kentucky

A unit of Sumitomo Construction Machinery Co., Ltd.

© Link-Belt is a registered trademark. Copyright 1996. We are constantly improving our products and therefore reserve the right to change designs and specifications.