



35100C

STANDARD COMPONENTS INCLUDE:

Boom, boom hoist cylinder, 2-speed winch, load line and 5 Ton (4,5 mt) overhaul ball, turret, pedestal, sub-frame, dual operator control stations, LMI & ATB protection systems, load chart for multiple spread outriggers, out-down outriggers, out-down rear stabilizers, hydraulic reservoir and boom rest.

HYDRAULICS

- 8-Bolt direct mounted PTO with SAE C output
- Three-section vane pump, SAE C input

Pump Section	2000 RPM	2000 RPM
Shaft End Pump:	38.4 GPM @ 100 PSI	145 LPM @ 100 PSI
Center Pump:	27.4 GPM @ 100 PSI	104 LPM @ 100 PSI
Cover End Pump:	11.2 GPM @ 100 PSI	42 LPM @ 100 PSI

- Hydraulic reservoir - 115 gallon (435 liter) capacity

WARNING SYSTEMS

- Wireless LMI with display and crane function shut-offs for overload protection
- Wireless anti-two block system

OPTIONS

- Wired LMI and ATB system
- 22' (6,7 m) Flatbed - wood or 1/8" steel deck
- 22' (6,7 m) Heavy hauler flatbed - 3/16" steel deck w/rub rails
- 24" (610 mm) Bulkhead
- 30'-6" (9,3 m) 1-Section fixed jib
- 30'-6" (9,3 m) - 55' (16,8 m) 2-Section telescopic jib
- Wire rope type 6 x 25 EIPS IWRC
- Load block - 1 & 3 sheave options
- Front center stabilizer for 360° work area
- Gear pump

BOOM

- 35 Ton (31,8 mt) capacity @ 6' (1,8 m) radius
- 4-Section 100' (30,5 m) proportional boom
- 5-Sheave quick reeve boom point

HOIST

- Maximum theoretical line speed 453 fpm (138 mpm)
- Maximum theoretical bottom-layer line pull 14,500 lb (6,577 kg)
- Wire Rope – 380' (115,8 m) 5/8" (16 mm) diameter, rotation resistant

In order to ensure continuous improvement, Manitex reserves the right to change design and specifications without notice.

- Auxiliary sheave block for up to 8 part line reeve
- Hydraulic oil cooler
- Hose reel - boom mounted
- Toolboxes
 - 24" L x 20" W x 18" H (610 mm x 508 mm x 457 mm)
 - 48" L x 18" W x 18" H (1,220 mm x 457 mm x 457 mm)
- 2-Person gravity leveled non-rotating basket - 600 lb (272 kg) capacity
- 2-Person gravity leveled rotating (manual) basket - 1,200 lb (544 kg) capacity
- 4-Function radio remote crane control system

MTX-35100C-SS-EN-V3-1111

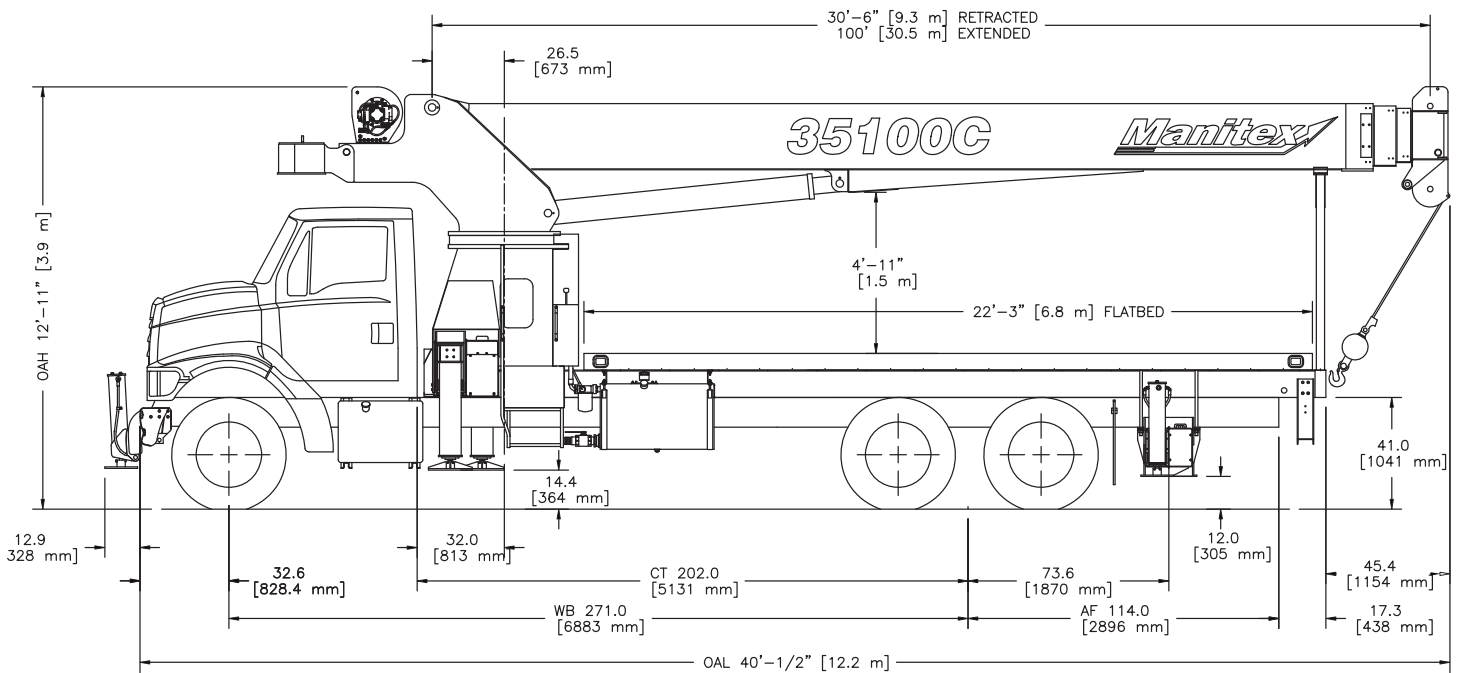

CHASSIS DATA	35100C
Wheelbase (WB)	271" 6 883 mm
Cab to Axle (CA)	202" 4 877 mm
After Frame (AF)	114" 2 896 mm
Frame Section Modulus for 360° Rotation (Minimum)	30.0 in ³ 125,000 psi 861 875 kPa
Front Axle Gross Weight Rating	20,000 lb 8 165 kg
Rear Axle Gross Weight Rating	40,000 lb 18 144 kg
Minimum Truck Axle Weight - Front**	8,450 lb 3 674 kg
Minimum Truck Axle Weight - Back**	8,300 lb 3 765 kg
Nominal Frame Width	34" 864 mm
**Minimum chassis weight is required to meet 85% stability requirements. Chassis data is general-not for engineering. Some dimensions depend on truck selection.	
WEIGHTS	35100C
Total Crane - Out-and-Down Outriggers	29,706 lb 13 502 kg
22' (6,71 m) Flat Bed	2,000 lb 907 kg
Telescopic Jib 30' 6" - 55' (9,30 m - 16,80 m)	1,754 lb 796 kg
30' 6" (9,30 m) Fixed Length Jib	1,126 lb 511 kg
*Flatbed weight not included in crane weight.	
MAXIMUM TIP HEIGHT (A)	35100C
Configuration	Boom 100' 30,5 m
Extended Boom	111' 4" 33,9 m
Fixed or Retracted Jib	142' 1" 43,3 m
Extended Jib	166' 8" 50,8 m

